

- 1 MATES WITH AMP CONNECTOR PART NO. 480706.
- △2 FLAME RETARDANT CLASSIFICATION OF MATERIAL IS 94V-2.
- 3 PARTS MUST COMPLY WITH AMP SOLDERABILITY SPEC 109-11-3.
- △4 CONTACT IS STAMPED FROM PRE-PLATED STOCK WHICH IS PLATED OVERALL WITH 0.00127 [.000050] NICKEL, THEN STRIPED WITH 0.00076 [.000030] GOLD IN CONTACT AREA INDICATED AND TIN-LEAD ON SOLDER TAIL END.
- △5 CONTACT IS PLATED OVERALL WITH 0.00127 [.000050] NICKEL, THEN 0.00076 [.000030] GOLD OVER CONTACT LENGTH INDICATED AND MATTE TIN ON SOLDER TAIL END.

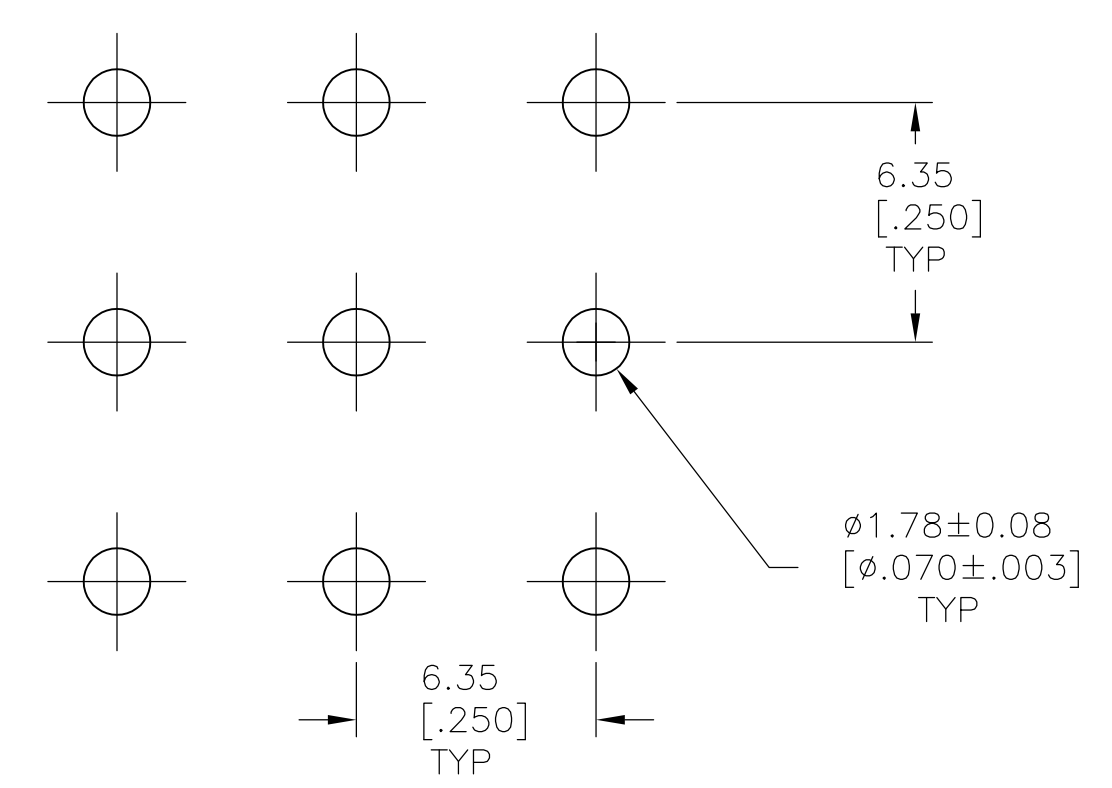

RECOMMENDED LAYOUT FOR 3.18 [.125] THICK PC BOARD

|                |                   |          |
|----------------|-------------------|----------|
| PH BRZ GOLD △5 | NYLON, NATURAL △2 | 350990-5 |
| PH BRZ TIN     | NYLON, NATURAL △2 | 350990-4 |
| PH BRZ GOLD △4 | NYLON, NATURAL △2 | 350990-3 |
| CONTACT        | HOUSING           | PART NO  |

|  |                   |  |   |                    |
|--|-------------------|--|---|--------------------|
| THIS DRAWING IS A CONTROLLED DOCUMENT. |                   | DWN: K. WHITAKER 11OCT2005   | Tyco Electronics Corporation<br>Harrisburg, PA 17105-3608 |                    |
| DIMENSIONS: mm [INCHES]                |                   | CHK: S. RIDGILL 11OCT2005  | APPROV: S. RIDGILL 11OCT2005                              |                    |
| TOLERANCES UNLESS OTHERWISE SPECIFIED: |                   | NAME: SOCKET HEADER ASSEMBLY<br>9 CIRCUIT, LONG TAIL,<br>UNIVERSAL MATE-N-LOK (TM) |   |                    |
| 0 PLC ±                                | 1 PLC ±           | PRODUCT SPEC   |   |                    |
| 2 PLC ±                                | 3 PLC ±           | APPLICATION SPEC   |   |                    |
| 4 PLC ±                                | ANGLES ±          | SIZE: A1   | CAGE CODE: 00779  | DRAWING NO: 350990 |
| MATERIAL: SEE TABLE                    | FINISH: SEE TABLE | WEIGHT:  | RESTRICTED TO:  |                    |
| CUSTOMER DRAWING                       |                   | SCALE: 5:1   | SHEET: 1 OF 1   | REV: G1            |

METRIC